

[giunto di riduzione | reduction joint]

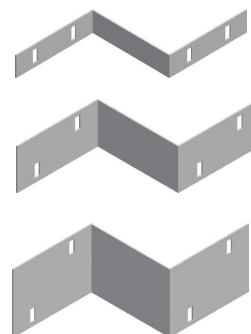
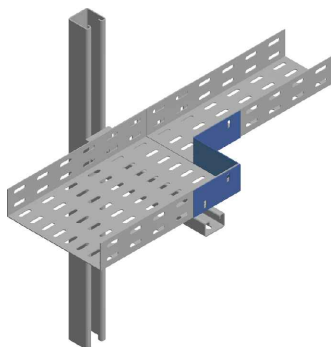
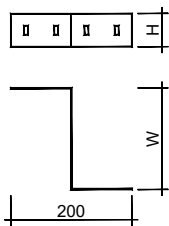

ELEMENTO | ELEMENT

CODICE | CODE

Descr.	H	W	Th	HDG	AISI 304	AISI 316
PFL25-GR-50	25	50	1	AZGR0001BDU	AIGR0001BDU	AYGR0001BDU
PFL25-GR-50	25	50	1,2	AZGR0001BDV	AIGR0001BDV	AYGR0001BDV
PFL50-GR-50	50	50	1,2	AZGR0001BDW	AIGR0001BDW	AYGR0001BDW
PFL50-GR-100	50	100	1,2	AZGR0002BDW	AIGR0002BDW	AYGR0002BDW
PFL50-GR-150	50	150	1,2	AZGR0003BDW	AIGR0003BDW	AYGR0003BDW
PFL50-GR-200	50	200	1,2	AZGR0004BDW	AIGR0004BDW	AYGR0004BDW
PFL50-GR-250	50	250	1,2	AZGR0005BDW	AIGR0005BDW	AYGR0005BDW
PFL50-GR-50	50	50	1,5	AZGR0001AMV	AIGR0001AMV	AYGR0001AMV
PFL50-GR-100	50	100	1,5	AZGR0002AMV	AIGR0002AMV	AYGR0002AMV
PFL50-GR-150	50	150	1,5	AZGR0003AMV	AIGR0003AMV	AYGR0003AMV
PFL50-GR-200	50	200	1,5	AZGR0004AMV	AIGR0004AMV	AYGR0004AMV
PFL50-GR-250	50	250	1,5	AZGR0005AMV	AIGR0005AMV	AYGR0005AMV
PFL75-GR-100	75	100	1,2	AZGR0002BDX	AIGR0002BDX	AYGR0002BDX
PFL75-GR-200	75	200	1,2	AZGR0004BDX	AIGR0004BDX	AYGR0004BDX
PFL75-GR-300	75	300	1,2	AZGR0006BDX	AIGR0006BDX	AYGR0006BDX
PFL75-GR-400	75	400	1,2	AZGR0008BDX	AIGR0008BDX	AYGR0008BDX
PFL75-GR-100	75	100	1,5	AZGR0002BDY	AIGR0002BDY	AYGR0002BDY
PFL75-GR-200	75	200	1,5	AZGR0004BDY	AIGR0004BDY	AYGR0004BDY
PFL75-GR-300	75	300	1,5	AZGR0006BDY	AIGR0006BDY	AYGR0006BDY
PFL75-GR-400	75	400	1,5	AZGR0008BDY	AIGR0008BDY	AYGR0008BDY

A Richiesta. Materiale: Alluminio - Finitura: Verniciatura - Spessore (Th): 1,0 - 1,2 - 1,5 - 2 mm. On request. Material: Aluminium - Finish: Paint job - Thickness (Th): 1,0 - 1,2 - 1,5 - 2 mm.